



# **GUIDELINES ON ROOFTOP SOLAR PV INSTALLATION FOR UTILITY PROVIDERS**

(Based on: CEB Manual for Interconnection of  
Micro Scale Renewable Energy Based Power  
Generating Facilities at Low Voltage Consumer  
Feeders of National Grid- August 2016)

April 2019

## **Preface**

This document provides a general guideline and best practices guide for the installation of rooftop solar PV systems in Sri Lanka. The guide was prepared based on the applicable international standards and best industry practices around the world. This document would provide a guideline to interconnection of rooftop solar PV power generating facilities at Low Voltage Consumer Feeders of National Grid. This document would provide a guide for utilities to assess the technical compatibility and quality of installation of a proposed or an installed solar PV system and procedure of interconnecting rooftop solar PV power generating facilities.

## List of Abbreviations

a.c	alternating current
BS	British Standard
CEB	Ceylon Electricity Board
d.c.	direct current
ER	Engineers Recommendation
GOSL	Government of Sri Lanka
I	Current
ITHD	Current Total Harmonic Distortion
IEC	International Electrotechnical Commission
IEEE	Institute of Electrical and Electronic Engineers
LECO	Lanka Electricity Company
PCC	Point of Common Coupling
PV	Photo Voltaic
PUCSL	Public Utilities Commission
RCD	Residual Current Device
SPD	Surge Protective Device
STC	Standard Test Conditions
TDD	Total Demand Distortion
V	Voltage
VTHD	Voltage Total Harmonic Distortion

## List of Definitions

**Producer:** A person or a company who owns a generating facility to produce and deliver electrical energy to the distribution network of CEB and presently owns a valid account receiving electricity from CEB distribution network.

**Import of Electrical Energy:** Receipt of Electrical Energy by the Producer from the CEB system.

**Export of Electrical Energy:** Supply of Electrical Energy by the Producer to the CEB system.

**Net Energy Metering:** Net Energy Metering means the measurement of the difference between electrical energy supplied through the electricity distribution network of CEB to the Producer and the amount of electrical energy generated by the Producer's Generating Facility delivered to the electricity distribution network of CEB.

**Net Accounting:** Net Accounting means the payment for the difference between electrical energy supplied through the electricity distribution network of CEB to the Producer and the amount of electrical energy generated by the Producer's Generating Facility through Solar PV delivered to the electricity distribution network of CEB.

**Net Plus:** Net Plus means the consumer generates electricity through Solar PV connected to the National grid with no linkage in-between the electricity consumption of the producer.

**Generating Facility:** Generating Facility means all of the Producer's equipment and land at a single site or parcel of land utilized to produce and deliver electrical energy, including but not limited to, Producer's generating, metering and protection equipment.

**Contract Demand:** The allocated capacity, as depicted in the electricity agreement, to the Consumer by the CEB expressed in terms of kilovolt ampere.

**Billing Period:** The period for which the Producer's electricity meter is read by CEB and the Consumer is issued with an electricity bill, usually a period of one month (30 days).

**Energy Credit:** This shall be the amount of net electrical energy exported to the CEB distribution network during a specified Billing Period, which amount, measured in kilowatt hours, shall be credited to the Producer's electricity account in the subsequent Billing Period.

**Parallel Operation:** The operation of the Generating Facility and producing electrical energy at the Consumer's premises, while connected to the CEB distribution network.

# Table of Contents

- List of Definitions.....4
- 1. BACKGROUND:.....7
- 2. NET METERING SCHEMS.....7
  - 2.1. SCHEME 01 - NET METERING .....7
  - 2.2. SCHEME 02 - NET ACCOUNTING .....8
  - 2.3. SCHEME 03 – NET PLUS .....9
- 3. PROCEDURE & APPLICATION PROCESS.....11
- 4. GENERAL RULES, RIGHTS AND OBLIGATIONS.....13
- 5. GENERATING FACILITY DESIGN AND OPERATING REQUIREMENTS .....15

## **1. BACKGROUND:**

The 'Battle for Solar Energy' program launched by the government to encourage the consumers to join in power generation by installing small solar power plants established on the rooftops of their houses to meet their energy requirements. It is expected to add 200 MW of solar electricity to the national grid by 2020 and 1000 MW by 2025 through this intervention.

Under this program, the consumers will have options to generate and use electricity in their premises under the "Net Metering" scheme. The initial Net Metering Concept launched in the year 2010. In order to support the GOSL's renewable energy promotional drive, the Net Metering Concept was further enhanced by introducing new three schemes. According to the electricity usage the roof top solar PV installation customer can select a preferred option from the three schemes: Net Metering, Net Accounting and Micro Solar Power Producer.

In accelerating the program, PUCSL conducted a stakeholder consultation to gather the views of the stakeholders in the industry. As part of the solution to the issues raised by the stakeholders, this guideline is prepared for utility providers to improve the existing framework. Therefore, "CEB Manual for Interconnection of Micro Scale Renewable Energy Based Power Generating Facilities at Low Voltage Consumer Feeders of National Grid- August 2016" is taken as the existing framework to develop this guideline.

## **2. NET METERING SCHEMS**

### **2.1. SCHEME 01 - NET METERING**

This scheme allows any electricity consumer to install a roof top solar PV installation and connect it to the national electricity network.

The utility energy meter will be replaced with an Import/Export meter. The electrical energy consumed from the grid is considered as import energy and electrical energy generated and supplied to the grid is considered as export energy.

At the end of each billing period (typically one month), utilities will read the consumer's

export energy meter reading and the import meter reading. The electricity bill will be prepared giving credit to the export and charging the consumer for the difference between the import and the export. If the export is more than the import in any billing period, the Consumer will receive an export credit, and will be credited towards his next month's consumption. Such credits may be carried-over to subsequent months, as long as there is no change in the legal consumer for the premises.

The key factor in this process is that there will be no financial compensation for the excess energy exported by the consumer. All exports will be set-off against the consumer's own consumption, either in the current billing period or future billing periods. Accordingly, consumers will be compelled to select the capacity of the renewable energy equipment to reasonably match his requirements.

The installed capacity of the Generating Facility shall not exceed the Contract Demand of the Producer. The contract period for the scheme is 20 years.

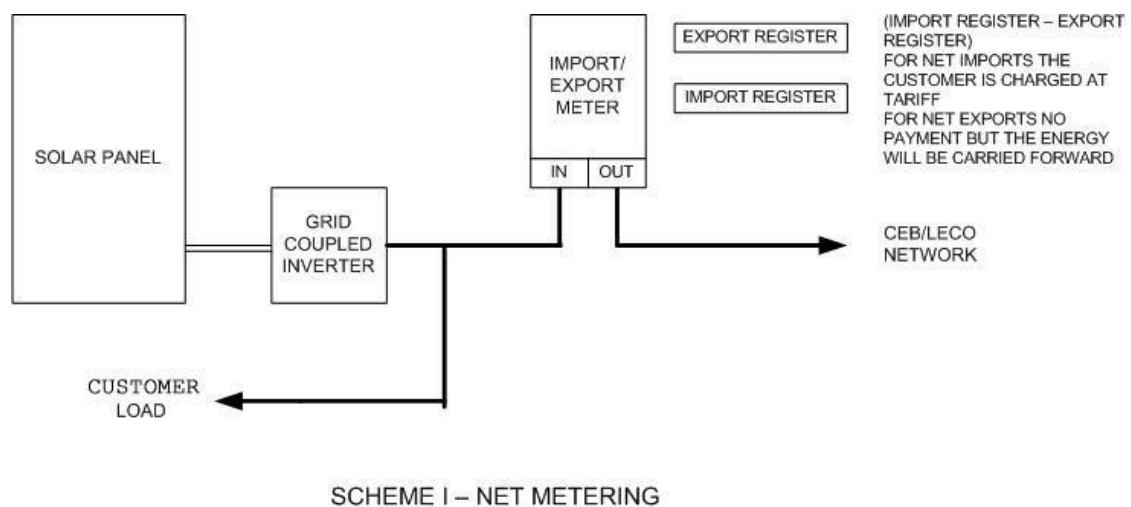

Figure 1: Typical connection arrangement for the Scheme 1 is given in the Annexure 01.

## 2.2. SCHEME 02 - NET ACCOUNTING

This Scheme has introduced an additional element to the Scheme 01 where an export tariff for



the net energy exported (if any) was introduced. If the generated units of electricity using the solar panels fixed in the roof are greater than the units consumed, the customer will be paid Rs

22.0 per unit during the first 07 yrs and from the 08<sup>th</sup> year to 20<sup>th</sup> year he will be paid Rs 15.50 per unit (subjected to changes). If the consumption is greater than the energy generated from the solar panels, consumer has to pay to the CEB at the existing electricity tariff for the excess energy consumed. This Scheme is limited only for the Solar.

The installed capacity of the Generating Facility shall not exceed the Contract Demand of the Producer. The contract period is 20 yrs.

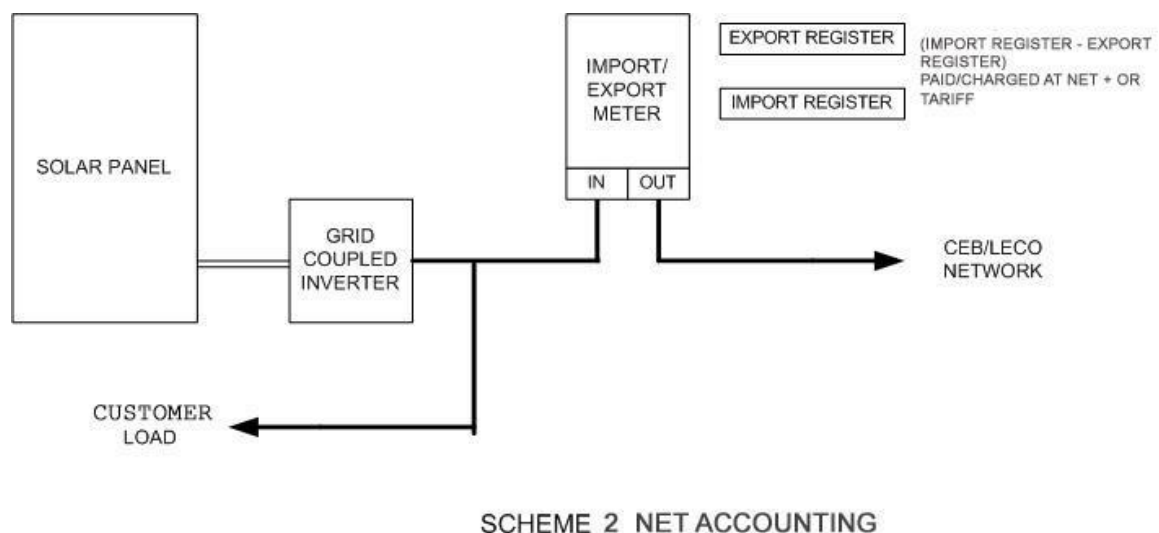

Figure 2: Typical connection arrangement for the Scheme 2 is given in the Annexure 01.

### 2.3. SCHEME 03 – NET PLUS

Total generation of electricity from the solar PV power plant will be exported directly through a dedicated meter for which the customer will be paid. The energy import will be measured through a separate import meter and will be billed as per the existing electricity tariff.

CEB shall read the meter to read the solar power plant output and the other meter to read the import energy. Total generation of electricity from the solar PV power plant will be exported directly through a dedicated meter for which the customer will be paid Rs 22.0 per unit during

the first 07 yrs and from the 08<sup>th</sup> year to 20<sup>th</sup> year the customer will be paid Rs 15.50 per unit (subjected to changes). The energy import will be measured through a separate import meter and will be billed as per the existing electricity tariff CEB.

The installed capacity of the Generating Facility shall not exceed the Contract Demand of the Producer. The contract period is 20 yrs.

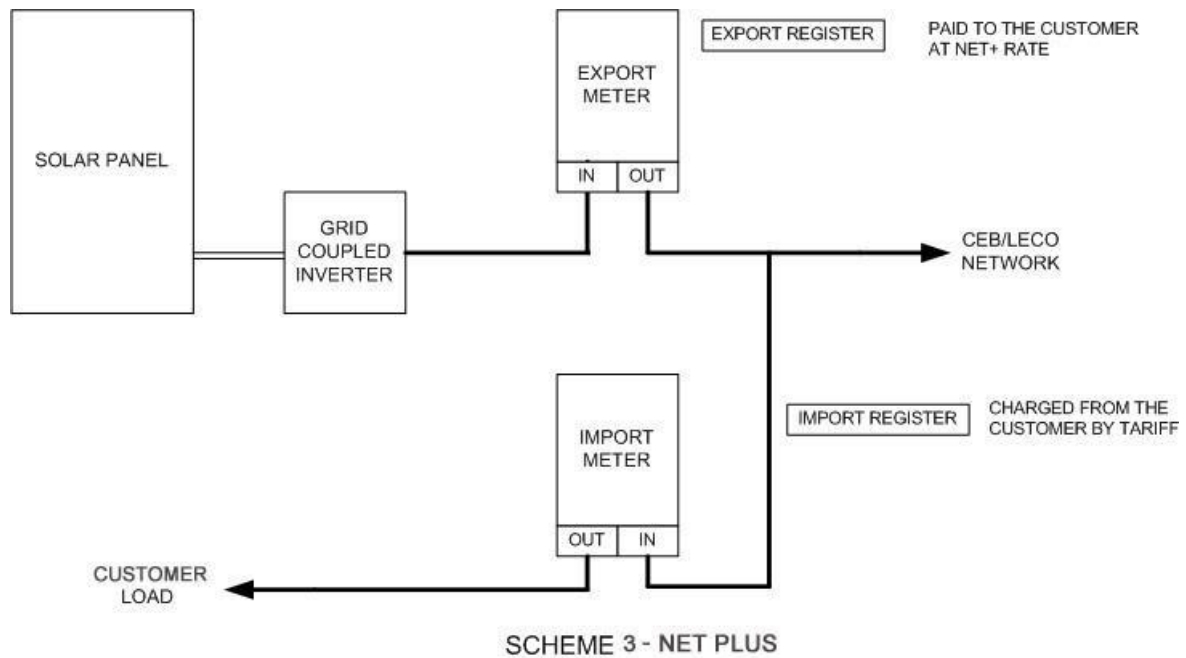

Figure 3: Typical connection arrangement for the Scheme 3 is given in the Annexure 02.

In Net Plus Scheme, the solar PV electricity generation facility shall be metered separately. The solar PV inverter output (generation facility output) should be brought to the metering point where both import and export energy meters are located in a separate meter cubical. The meter cubicle should be sealed properly to avoid tampering. If the space of the existing meter location is not sufficient to install another meter for energy export, the consumer should make necessary arrangements to shift the metering point to a suitable location in consultation with relevant Area Chief Electrical Engineer/ Area Engineer/Provincial Commercial Engineer. The cost associated for shifting the meter to a new location should be charged at the prevailing rate from the consumer.

### 3. PROCEDURE & APPLICATION PROCESS

- 3.1. Potential Applicant initiates contact with the respective CEB/LECO Area Engineer. Upon request CEB/LECO will provide Application and Agreement and Interconnection Standard including technical information, initial review information, metering requirement etc to a potential Producer (These documents can also be downloaded from the PUCSL website).
- 3.2. Applicant completes the Application and files Application and supply any relevant additional information requested by CEB/LECO. Initial review fee is to be paid at the time of handing over the Application for processing.
- 3.3. CEB/LECO performs an Initial Review and develops preliminary cost estimates and interconnection requirements. The maximum acceptable time to provide the estimate for net meter installation shall be **ONE week** from the date of submission of the duly filled net metering application with relevant application fee.
- 3.4. Applicant and CEB/LECO enter into an Interconnection Agreement.
- 3.5. Producer arranges for and completes commissioning testing of generating facility and Producers interconnection facilities by an listed competent Electrical Engineer or a qualified technician as per “National Guideline on Rooftop Solar PV installation for Service Providers”, IEC 61727 (2004 -12), IEEE 1547 – 2018, IET 18<sup>th</sup> Edition Wiring Regulations or latest available equivalent Standards at Producers cost and the same is witnessed by the CEB/LECO Engineer or competent representative. Facility testing shall be conducted at a mutually agreeable time.  
The maximum acceptable time to provide net metering installation and grid connection with signing the agreement shall be **ONE week** from receiving the payment for net meter installation.
- 3.6. Parallel operation shall be authorized, after successful commissioning testing and execution of Agreement.

Flow chart on the procedure and application process is given below.

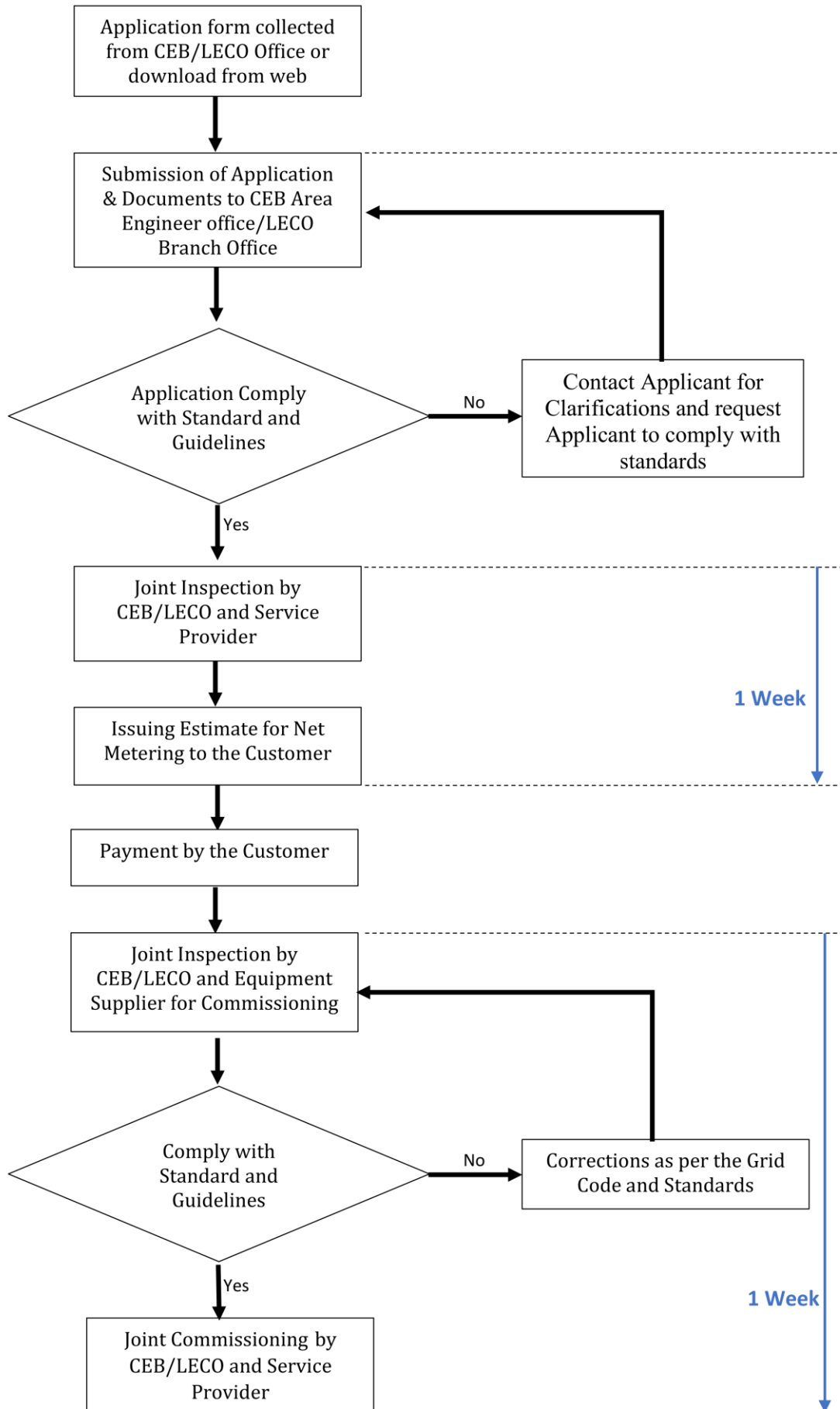

1 Week

1 Week

#### **4. GENERAL RULES, RIGHTS AND OBLIGATIONS**

- 4.1. The Generating Facility shall use one or any combination of the approved types of renewable sources of energy to generate electricity at the Producer's premises in respect of Scheme 01. However, generating facility shall be solar for Schemes 02 and 03.
- 4.2. The entire Generating Facility and equipment such as solar panels and associated accessories such as inverters and protective circuits shall be located within the Producer's premises and shall be owned by the Producer.
- 4.3. A Producer must comply with the conditions imposed by the CEB/LECO which is depicted in the Agreement and Interconnection Standard and written permission should be taken from CEB/LECO before parallel operation.
- 4.4. The Generating Facility shall be intended to meet all or a part of the Producer's electricity demand (maximum allowable limit is the contract demand of the Producer) and electrical energy requirements. It shall be the responsibility of the Producer to decide on the capacity of Generating Facility with due consideration to the amount of renewable energy available, investment and operating costs of equipment, the Producer's Contract Demand and the average electrical energy requirements of the Producer.
- 4.5. Interconnection with distribution system under the agreement does not provide the Producer any rights to utilize HV/LV distribution system for the transmission, distribution or wheeling of electric power to a third party.
- 4.6. A Producer shall ascertain and comply with applicable rules, regulations imposed by the Ministry of Power and Energy / CEB/ LECO / Public Utilities Commission of Sri Lanka (PUCSL)/ Sri Lanka Sustainable Energy Authority (SEA) and any law or standard that applies to the design, construction, installation, operation or any other aspect of the Producers Generating Facility and interconnection facilities.
- 4.7. CEB/LECO shall have the right to review the design of Producer's generating and interconnection facilities and to inspect such facilities prior to the commencement of parallel operation with distribution system. Producer may require to make modification as necessary to comply with the utility requirements.
- 4.8. The authorization for parallel operation shall not be construed as conforming or endorsing the Producers design or as warranting the Generating and or interconnection facility's safety, durability or reliability. By reason of such review or lack of review, CEB/LECO be responsible for the strength, adequacy or capability of such equipment.

- 4.9. The installed capacity of the Generating Facility shall not exceed the Contract Demand of the existing installation (Installed generation capacity is defined as the maximum power of the inverter). If the Producer so wishes to increase or decrease his Contract Demand, he shall first apply to change his Contract Demand as a Consumer, and after fulfilling the requirements specified by CEB/LECO, request an amendment to this Agreement. In any event, the Term of this Agreement shall be limited to twenty years from the date of execution.
- 4.10. The Generating Facility shall be built and operated according to the relevant standards and other guidelines stipulated in the Agreement.
- 4.11. The Producer shall make sure that the inverter (s) carry a Type Test Certificates as applicable from a third party accredited laboratory.
- 4.12. The Producer shall install all the necessary protective equipment required to ensure safe and reliable operation of the Generating Facility and the Producer shall meet all the expenses of installing such equipment and other associated accessories.
- 4.13. The Producer shall maintain all the equipment downstream of the metering equipment in good operating condition.
- 4.14. The Producer shall allow CEB/LECO representatives to enter his premises for the inspection of the metering equipment and the Generating Facility and would promptly attend to and implement any written recommendations or instructions with regard to the Generating Facility.
- 4.15. Any information pertaining to Generating and/or interconnection facilities provided to CEB/LECO by a Producer shall be treated by CEB/LECO in a confidential manner.
- 4.16. A Producer shall operate and maintain its Generating Facility and Interconnection Facilities in accordance with Prudent Electrical Practices.
- 4.17. Utilities may limit the operation or disconnect or require the disconnection of a Producer's Generating Facility from the distribution system at any time with or without notice, in the event of an emergency or to correct unsafe operating conditions. Utilities may also limit the operation or disconnect or require the disconnection of a Producers Generating facility from the distribution system upon the provision of reasonable notice.
- 4.17.1. to allow for routine maintenance, repairs or modifications to CEB distribution system.
- 4.17.2. Upon CEB determination that a Producer's Generating Facility is not in

compliance with the conditions stipulated in the Agreement

4.17.3. Upon termination of Interconnection Agreement.

4.18. Prior to signing the agreement, the Producer shall provide technical literature including Type Test certificates of the protective equipment for Net Energy Metering to the CEB and shall obtain the concurrence of the CEB to procure the same.

4.19. CEB/LECO shall promptly install the meters and metering equipment to implement Net Energy Metering, the initial cost of which shall be paid by the Producer.

4.20. CEB/LECO shall maintain the distribution network and the metering equipment to supply and meter the electricity requirements of the Producer, and to accept the electricity generated by the Producer, up to the capacity stated in the supply agreement and this Agreement, respectively.

4.21. CEB/LECO shall promptly (within 1 weeks) attend to Producer's requests for testing the meters or metering equipment for their accuracy, the fees for which shall be payable by the Producer.

4.22. CEB/LECO shall promptly read the Producer's meter at the end of each Billing Period, bill the Consumer for his net energy consumption in the Billing Period after giving due consideration to the credits from the previous Billing Period, and credit the energy exported to the Consumer's account to be carried over to the next Billing Period. Monthly invoice shall show the export energy credit carried over from the previous Billing Period, consumption and export in the present Billing Period, and the energy credit carried over to the subsequent Billing Period (all figures in kilowatt hours).

4.23. Payment shall be made to the Consumer, after deducting the charges due from him, within 30 days of the meter reading of each billing period.

## **5. GENERATING FACILITY DESIGN AND OPERATING REQUIREMENTS**

5.1. The protective function and requirements defined here are designed to protect CEB distribution system and not the Generating Facility. A Producer shall be solely responsible for providing adequate protection for its Generating Facility and interconnection facilities. The Producer's protective functions shall not impact the operation of other protective functions utilized on CEB's distribution system in a manner that would affect CEB capability of providing reliable service to its customers.

5.2. Generating facilities operating in parallel with the distribution system shall be equipped with the following protective functions to sense abnormal conditions on CEB distribution system and cause generating facility to be automatically disconnected from the distribution system or to prevent the generating facility from being connected to the distribution system inappropriately.

5.2.1. Utility Distribution System Parameters are as follows;

Nominal Voltage	33 kV	11kV	400 V
System Highest Voltage	36 kV	12 kV	440 V
Rated fault current	25 kA	20 kA	20 kA
No. of Phases	3	3	3ph& Neutral
System Frequency	50Hz	50Hz	50Hz
Method of Earthing	Non Effectively Earthed	Solidly Earthed	Solidly Earthed

5.2.2. Over and Under Voltage trip functions and over and under frequency trip functions.

5.2.3. A voltage and frequency sensing and time delay function to prevent the generating facility from energizing a deenergized distribution system circuit and to prevent the generating facility from reconnecting with the distribution system unless the distribution system service voltage is within  $\pm 6\%$  of the nominal supply voltage and frequency is within 47 Hz to 52 Hz and are stable for at least 3 minutes.

5.2.4. A function to prevent the generating facility from contributing to the formation of an Unintended Island and cease to energize the grid within half a second (0.5 second) of the formation of an unintended island.

5.2.5. The generating facility shall cease to energize the distribution system for faults on distribution system circuit to which it is connected. (IEEE 1547 – 4.2.1). The generating facility shall cease to energize the distribution circuit prior to reclosure by the distribution system equipment. (IEEE 1547- 4.2.2).

5.3. The generating facility shall be automatically disconnected from the distribution network within half a second (0.5 second) when the supply is intentionally or automatically switched off.

5.4. Suitable equipment required.

Circuit breakers or other interrupting devices located at the point of common coupling must be certified by CEB/LECO as suitable for their intended operation. This includes



being capable of interrupting the maximum available fault current expected at their location. Producer’s generating facility and interconnection facilities shall be designed so that the failure of any one device shall not potentially compromise the safety and reliability of the distribution system.

The generating facility paralleling device shall be capable of with standing 220% of the interconnection facility rated voltage (IEEE 1547 – 4.1.8.3). The interconnection facility shall have the capability to withstand voltage and current surges in accordance with the environments defined in IEEE 1547 – 4.1.8.2

5.5. Visible disconnect at Point of Common Coupling (PCC)

The producer shall furnish and install an appropriately sized ganged isolating switch near the point of common coupling (PCC) to isolate the generating facility from the grid.

The device must:

- a. Allow visible verification that separation has been accomplished. (This requirement may be met by opening the enclosure to observe contact separation)
- b. Include marking or signage that clearly open and closed positions.
- c. Be secured in a weather-proof enclosure and capable of being locked in the open position prevent unauthorized or accidental closing.
- d. Be clearly marked on the submitted single line diagram and its type and location approved by CEB prior to installation.

5.6. Prior to parallel operation or momentary parallel operation of the generating facility, the Producers protective function shall be approved by the CEB/LECO. Generating facilities equipped with protective function and control scheme previously approved by CEB/LECO may satisfy this requirement by reference to previously approved drawings and diagrams.

5.7. The output voltage wave form of the Generating Facility shall be of 50 Hz, with a sinusoidal wave form.

5.8. The Harmonic Distortion limit at PCC shall be as follows.

The emission limits are given below;

<b>Parameter</b>	<b>Maximum Limit</b>
Voltage Total harmonic distortion (VTHD)	5%
Total Demand Distortion (TDD)	5%

Individual harmonic order(h)	3≤h<11	11≤h<17	17≤h<23	23≤h<35	35≤h<50
Allowable Limit in % of I <sub>L</sub>	4	2	1.5	0.6	0.3

Where,

$$VTHD = \frac{\sqrt{\sum_{h=2}^{h_{max}} V_h^2}}{V_1}, TDD = \frac{\sqrt{\sum_{h=2}^{h_{max}} I_h^2}}{I_L}$$

V<sub>1</sub> is the rms value of the fundamental voltage

I<sub>L</sub> is the rms value of the maximum load current of the inverter under normal operating condition

**Special Note:** Listed or previously certified **inverter models** are exempt from the harmonic test when appropriate documentation is available. **Previous certificates of inverter models are valid only for 18 months.**

5.9. The Producer shall make sure that the generation facility complies with the following Trip Settings;

Parameter	Symbol	Trip Setting	Clearances Time
Over Voltage 2	U>>	230 V + 10 %	0.2 s
Over Voltage 1	U>	230 V + 6 %	1.5 s
Under Voltage	U<	230 V - 6 %	1.5 s
Over Frequency	f>	50 Hz + 2 %	0.5 s
Under Frequency	f<	50 Hz - 6 %	0.5 s

5.10. The Producer shall make sure that, if the generation facility disconnects, it remains disconnected from the network until the voltage and frequency at the supply terminals has remained within the nominal limits for at least 3 minutes.

5.11. The Producer should not change any of the settings stated above without the written permission from the CEB.

5.12. The Power Quality at the Point of Common Coupling (PCC) shall be as follows; Power quality measurement shall be complied with IEC 61400-21. Emission of inter-harmonic currents from the power electronic converter up to 2 kHz and of current distortions above 2 kHz up to 9 kHz during operations shall be stated. The individual inter-harmonic currents below 2 kHz and the current distortions in the range 2 kHz up to 9 kHz shall be given as ten-minute average data for each frequency at the output power giving the maximum individual inter-harmonic current or current distortion.

5.13. Flicker

Standard applicable: As per IEC 61000-3-7

**ANNEXURE 01**

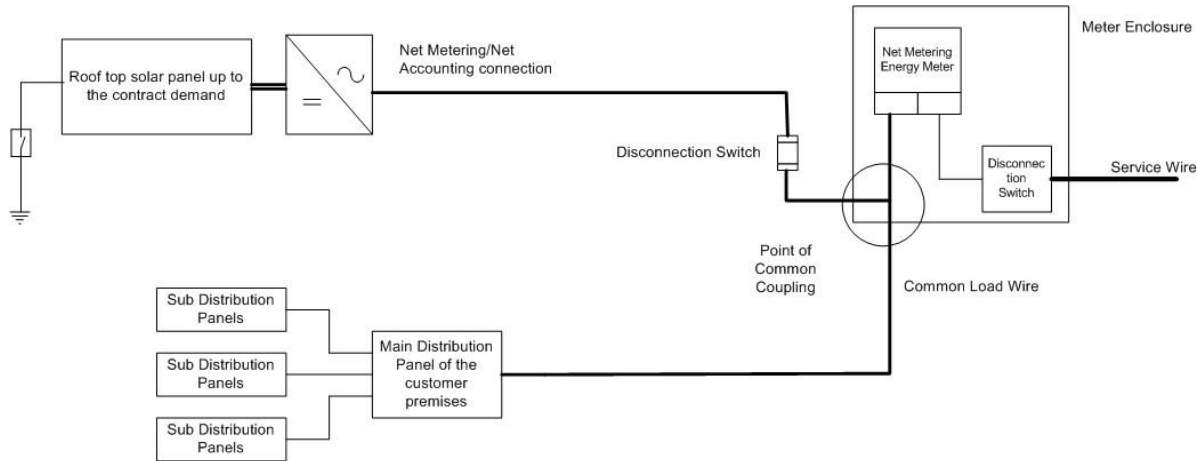

Electrical Layout for Net Metering and Net Accounting Installations

**ANNEXURE 02**

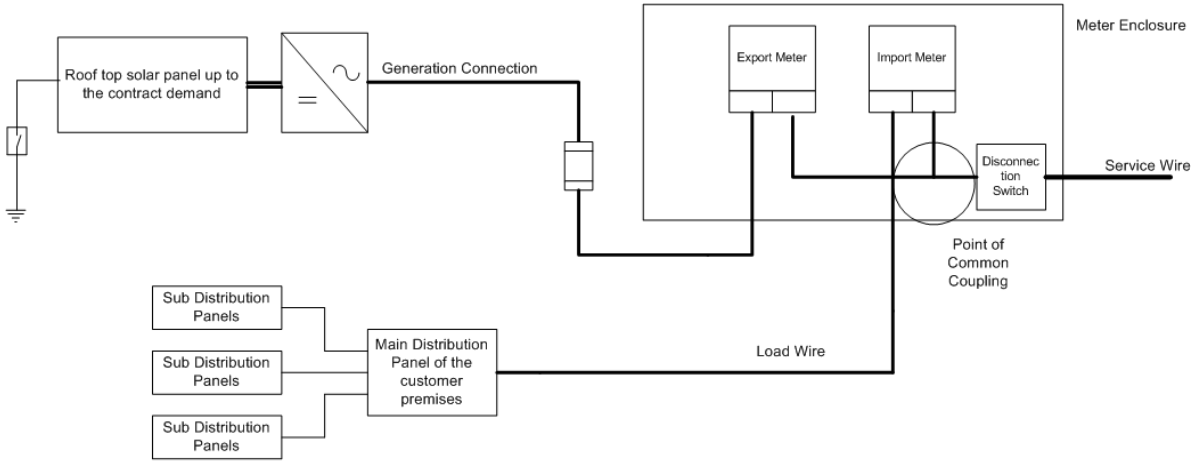

Electrical Layout for Net Plus Installations